



# **BirdDog** X4 Ultra Manual & Guide

APRIL · 2026



## FCC NOTICE (CLASS A)

---



This device complies with part 15 of the FCC rules. Operation is subject to the following two conditions: **(1)** this device may not cause harmful interference, and **(2)** this device must accept any interference received, including interference that may cause undesired operation.

The manufacturer is not responsible for any radio or TV interference caused by unauthorized modifications or changes to this equipment. Such modifications or changes could void the user's authority to operate the equipment.

This equipment has been tested and found to comply with the limits for a Class B digital device, pursuant to part 15 of the FCC Rules. These limits are designed to provide reasonable protection against harmful interference in a residential installation. This equipment generates uses and can radiate radio frequency energy and, if not installed and used in accordance with the instructions, may cause harmful interference to radio communications. However, there is no guarantee that interference will not occur in a particular installation. If this equipment does cause harmful interference to radio or television reception, which can be determined by turning the equipment off and on, the user is encouraged to try to correct the interference by one or more of the following measures:

- **Reorient** or relocate the receiving antenna.
- **Increase** the separation between the equipment and receiver.
- **Connect** the equipment into an outlet on a circuit different from that to which the receiver is connected.
- **Consult** the dealer or an experienced radio/TV technician for help.

### Federal Communication Commission (FCC) Radiation Exposure Statement

When using the product, maintain a distance of 20cm from the body to ensure compliance with RF exposure requirements.



### **WARNING**

Operating this equipment in a residential environment may cause radio interference.

### European Community Compliance Statement (Class A)



- RF exposure information: The Maximum Permissible Exposure (MPE) level has been calculated based on a distance of  $d=20$  cm between the device and the human body. To maintain compliance with RF exposure requirement, use product that maintain a 20cm distance between the device and human body.
- Bluetooth (2402–2480MHz) Max EIRP is 9.25dBm.
- Declaration of Conformity Hereby, You Tec Ltd declares that the radio equipment type X3 is in compliance with directive 2014/53/EU and RER 2017 (SI 2017/1206).

## TABLE OF CONTENTS

---

<b>Safety Precautions</b>	4
<b>What's in the Box</b>	4
<b>Product Connections</b>	5
<b>About the Product</b>	5
<b>Product Description</b>	6
<b>Technical Specifications</b>	7
<b>Wireless Function</b>	8
<b>Remote Control</b>	9
<b>Setup Guide</b>	10
<b>Installation</b>	11
<b>Connections and Configuration</b>	12
<b>Web Configuration Panel</b>	14
<b>Network Setup</b>	15
<b>AI Tracking from BirdUI</b>	17
<b>OSD Menu Overview</b>	20
<b>Camera Dimensions</b>	28
<b>Troubleshooting</b>	29
<b>Warranty</b>	30

## SAFETY PRECAUTIONS

---

- During the installation and operation, all electrical safety regulations of the country and region of use must be strictly observed.
- Please use the power adapter that comes standard with this product.
- Do not rotate the camera by hand, otherwise it may cause mechanical failure.
- When installing this product on a wall or ceiling, make sure the device is secured and there are no obstacles within the rotation range; Do not power on until installation is complete.
- To avoid overheating, please ensure adequate ventilation is provided to the camera.
- If the device malfunctions, makes unexpected noises or smells, turn off the power and unplug the power cord immediately. Contact your dealer for service.
- This device is designed for internal use only, and is not water resistant or waterproof.
- This product has no user serviceable parts, damage caused by disassembly by the user is not covered by the warranty.



### WARNING

Operating this equipment in a residential environment may cause radio interference.

## WHAT'S IN THE BOX

---

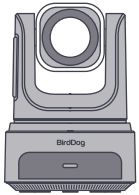

1x **PTZ Camera**



1x **IR Remote Controller**



1x **DC 12V Power Supply**



1x **Welcome Pack**

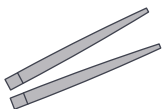

2x **Antennas**



**Rear Silicon Numbers**

## PRODUCT CONNECTIONS

---

1. Please check all connections before powering on.
2. Power on sequence of the camera involves rotating the lens body to the lower left limit, upper right limit, and finally settling in the HOME position. Once initialisation is complete, the camera is ready for general operation.

**Note:** If Preset position 0 is stored, the PTZ will automatically recall this position when finalising the startup procedure).

## ABOUT THE PRODUCT

---

### 4K UHD

X4 Ultra utilizes the latest generation High-Quality 1/1.8 UHD CMOS sensor delivering 4K UHD images (3840x2160), it is also compatible with 1080p and 720p formats.

### AI Tracking

Onboard AI processing delivers advanced auto-framing capabilities allowing the camera to automatically follow human shapes while moving. Additionally X4 Ultra supports Zone-based tracking to automatically move the camera to predetermined positions when someone enters or leaves the frame.

### 20x Optical Zoom + 60° Wide-angle Lens

X4 Ultra has a high-quality 4K 20x lens. With a wide field of view (60°) and up to 16x digital Zoom.

### NDI|HX3

NDI® | HX3 is the next generation of NDI network transmission with ultra-low latency, high quality images, easy network deployment, and expansive ecosystem. The NDI® | HX3 protocol supports transmission of Video, Audio and Control Signals.

### Wireless Transmission

X4 Ultra includes a WiFi 6 2x2 MIMO Transmitter capable of robust and long range wireless connectivity. It includes an easy management console to connect to your existing Wireless infrastructure.

### Multiple Control Method

You can control the X4 Ultra camera via multiple control protocols including RS232, Network (VISCA IP, NDI) and USB.

### Built in e-ink screen

Information is displayed on the onboard e-ink display including the devices network host name, IP address, current video format, Wireless signal strength and battery status.

## PRODUCT DESCRIPTION

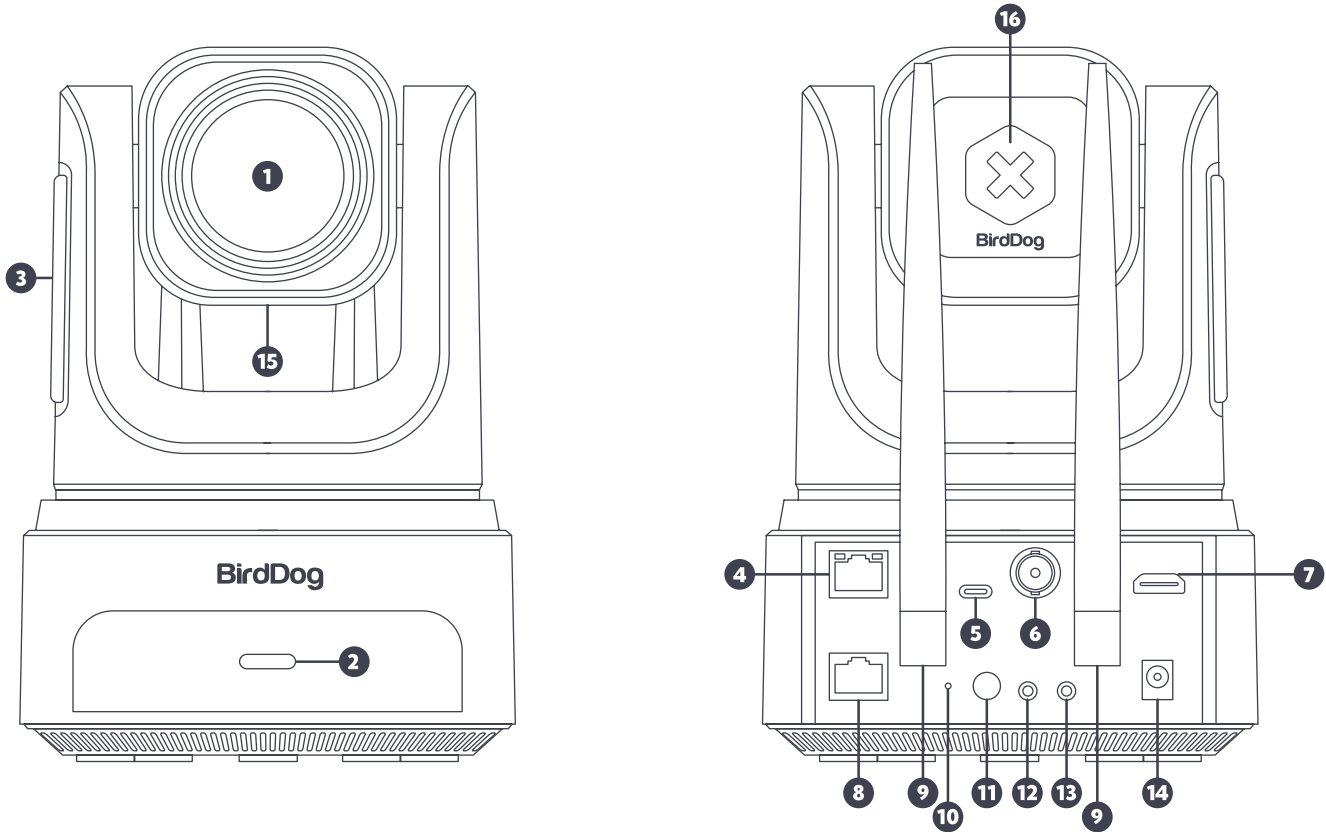

No.	Name
1	Lens
2	Power & Standby Indicator
3	Display (e-ink)
4	LAN/PoE+ <sup>(1)</sup>
5	USB-C <sup>(2)</sup>
6	3G-SDI Connector <sup>(3)</sup>
7	HDMI <sup>(4)</sup>
8	RS 232

No.	Name
9	Antenna Connectors
10	Reset Key
11	Power Key (Long Press On/Off)
12	Audio Out (3.5mm)
13	Audio In (3.5mm)
14	DC 12V
15	Tally Light
16	Rear Tally Light - Silicon Number

<sup>(1)</sup> VISCA over IP control and NDI® output. Requires PoE+ (IEEE802.3at).

<sup>(2)</sup> Camera video out streaming for UC communication software.

<sup>(3)</sup> Camera video out streaming for 3G-SDI.

<sup>(4)</sup> Camera video out streaming for HDMI.

## TECHNICAL SPECIFICATIONS PAGE

Feature	X4 Ultra
<b>IMAGING</b>	
<b>Image Sensor</b>	Sony 1 / 1.8" CMOS – ULTRA HD
<b>Lens</b>	f= 6.25- 125mm
<b>Optical Zoom</b>	20x
<b>Video Format</b>	2160p @ 60/59.94/50/30/29.97/25fps, 1080p @ 60/59.94/50/30/29.97/25fps, 1080i @ 59.94/50fps 720p @ 60/59.94
<b>Horizontal angle of view</b>	60° (W) – 3.5°(T)
<b>Vertical angle of view</b>	35° (W) – 2.0°(T)
<b>Diagonal angle of view</b>	66.6°(W) – 4.0°(T)
<b>Aperture</b>	F1.58 (W) ~ 3.95 (T)
<b>Focus</b>	Auto, Manual
<b>Exposure</b>	Auto, Shutter Priority,Iris Priority, Manual
<b>Shutter Speed</b>	1/1 – 1/10000s
<b>Backlight Compensation</b>	Yes
<b>Digital Noise Reduction</b>	3D Noise Reduction
<b>SNR</b>	≥45dB
<b>Effective Pixels</b>	8.42 MP
<b>AI Tracking</b>	Presenter tracking, Zone
<b>MECHANICAL</b>	
<b>Pan/Tilt Rotation</b>	±170°, -30° ~ +90°
<b>Pan Control Speed</b>	1.7–80°/sec
<b>Tilt Control Speed</b>	1.7–60°/sec
<b>Preset Number</b>	255 Presets
<b>Integrated Tally Light</b>	HALO tally and rear number tally system (Red/Green)
<b>Display</b>	e-Ink 2.13" with customization logo

Feature	X4 Ultra
<b>I/O INTERFACE</b>	
<b>Video Output Interfaces</b>	3G–SDI, HDMI,USB–C UVC, Network
<b>Analogue Audio</b>	3.5mm TRS Line input/Mic Input
<b>Network Interfaces</b>	1Gbps adaptive Ethernet port; PoE IEEE 802.3at, WiFi 6 2x2 MIMO (Optional Base station)
<b>Encoder Network Protocols</b>	NDI® HX2, NDI® HX3, RTSP, RTMP, SRT
<b>Control Interfaces</b>	1Gbps Ethernet, USB–C, RS–232
<b>Control Protocols</b>	VISCA Baud Rate: 38400/9600/4800/2400, VISCA–IP, NDI®, ONVIF
<b>GENERAL PARAMETER</b>	
<b>Environmental Operation</b>	Internal
<b>Input Voltage</b>	DC12v, PoE IEEE 802.3at
<b>Input Current</b>	5.0A (Max)
<b>Battery Capacity</b>	9450mAh
<b>Battery Operating Time (Per charge)</b>	~4h (usage dependent)
<b>Working Temperature</b>	0°C ~ +40°C
<b>Working Humidity</b>	20% ~ 80%
<b>Dimension (W*H*D) mm</b>	140.2*188.9*203.2mm/ 295*245*254mm (before / after packing)
<b>Dimension (W*H*D) in</b>	5.5*7.43*8.0in/ 11.6*9.6*10.0in(before / after packing)
<b>Net and Gross Weight</b>	2.19kg (Net Weight)

## WIRELESS FUNCTIONS

---

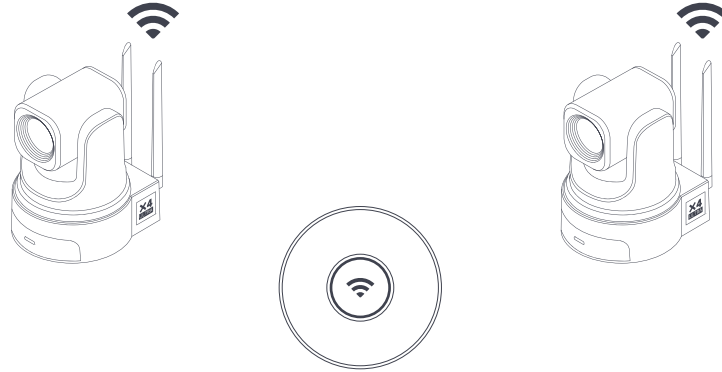

Wifi Access Point



The Camera can be paired directly to your Wi-Fi Router. Or you can use a separate Wi-Fi access point to extend your connection range to the canvas.



Connected to Router

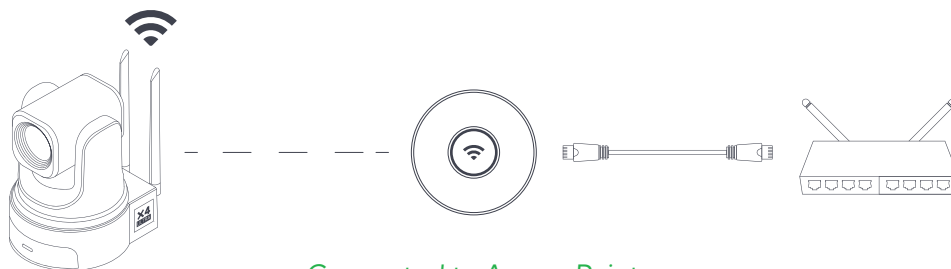

Connected to Access Point

## REMOTE CONTROL

### KEY DESCRIPTION

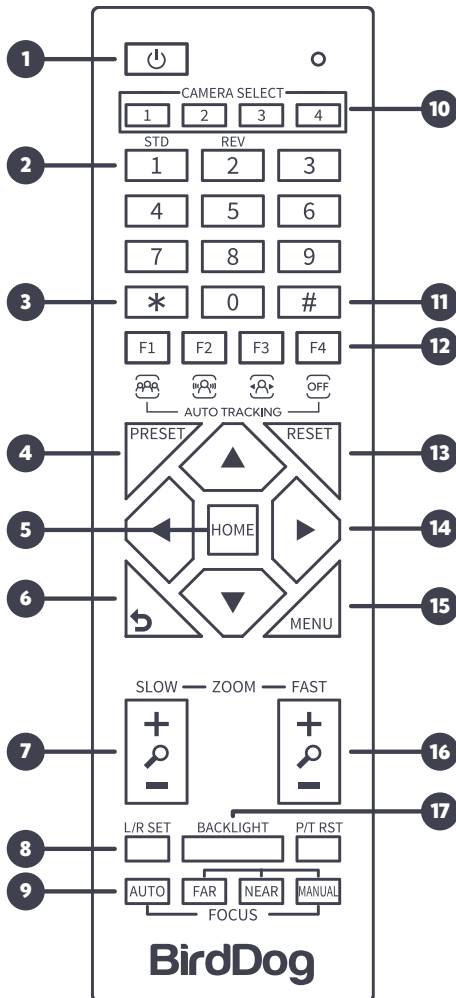

#### Shortcut Set

- **Successively press [#] + [\*] + [F4]:**  
Enable or disable the Image Freeze
  - **Successively press [\*] + [#] + [4]:**  
Display current IP address
  - **Successively press [\*] + [#] + [6]:**  
Quickly recover the default
  - **Successively press [\*] + [#] + [MANUAL]:**  
Restore to default IP address and password
  - **Successively press [\*] + [#] + [RESET]:**  
Clear all preset positions.
- Standby/Power On Key**  
Press to toggle Power status (ON/Standby).
  - Number Keys**  
Set and recall presets.
  - \* Key**  
Use in combination with other keys.
  - PRESET Key**  
Set preset: press [PRESET] + Number key (0-9).
  - HOME Key**  
Confirm selection or press to reset camera to default position.
  - Return Key**  
Press to return to the previous menu.
  - ZOOM Keys**  
SLOW: Zoom In [+] or Zoom Out [-] slowly.  
FAST: Zoom In [+] or Zoom Out [-] fast.
  - L/R SET Key**  
Standard: Simultaneously press [L/R SET] + 1.  
Reverse: Simultaneously press [L/R SET] + 2.
  - FOCUS Keys**  
Auto/Manual/Far/Near Focus.
  - CAMERA SELECT Keys**  
Press 1/2/3/4 to select camera.
  - # Key**  
Use in combination with other keys.
  - Auto Tracking Keys**  
[F1] and [F2]: Disable.  
[F3]: Turn on AI Tracking.  
[F4] Turn off AI Tracking.
  - RESET Key**  
Clear preset position: press [RESET] + Number key (0-9).
  - Menu Control Keys**  
Navigate OSD in the direction of the arrows.
  - MENU Key**  
Press to enter or exit OSD Menu.
  - BACKLIGHT Key**  
Turn on/off backlight compensation.
  - P/T RST (PTZ RESET) Key**  
Press to preset Pan/Tilt self-test.

## SETUP GUIDE

**Step 1:** Connect your camera directly to your network via PoE(1) or with the included DC Power adapter and a regular network connection. If you have a wireless receiver box, connect this to your network(2).

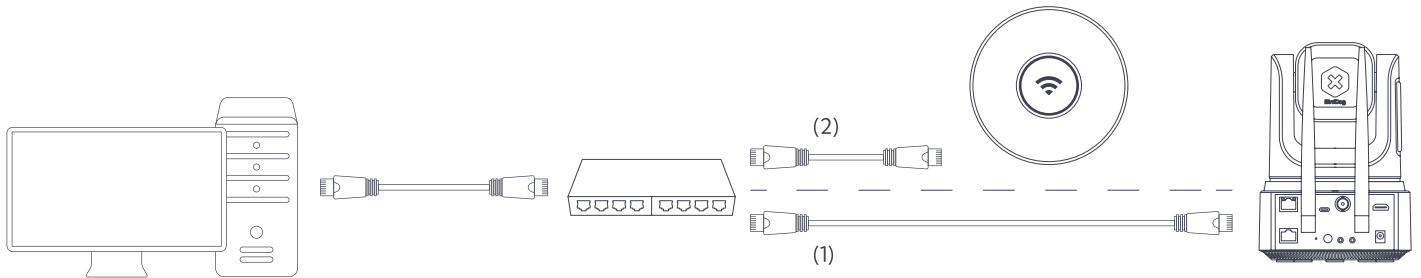

**Step 2:** Press the Power button on the rear of the camera for 3 seconds for the camera to initialize.

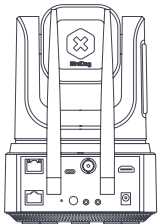

**Step 3:** View IP Address and basic camera status on the e-ink screen to verify the camera has started up.

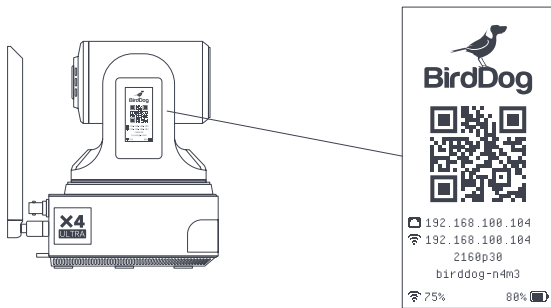

**Step 4:** For more settings, please visit the BirdUI Web configuration page.

  Dashboard	<b>BirdDog PTZ</b> X4 Ultra	<b>Device Mode:</b> Encode <b>Source Status:</b> Streaming NDI	
	 <b>System Utilization</b>	<b>Ethernet Status:</b> Not Connected <b>Wi-Fi Status:</b> Connected <b>Preferred NIC:</b> Wi-Fi	 <b>Wi-Fi Network</b> BD-Office 2.4GHz
<b>Status</b>			
NDI Video Stream Name: <b>CAM</b>		Video Format: <b>1080p60</b>	Audio Status: <b>Mute</b>

## INSTALLATION

### Wall Mount

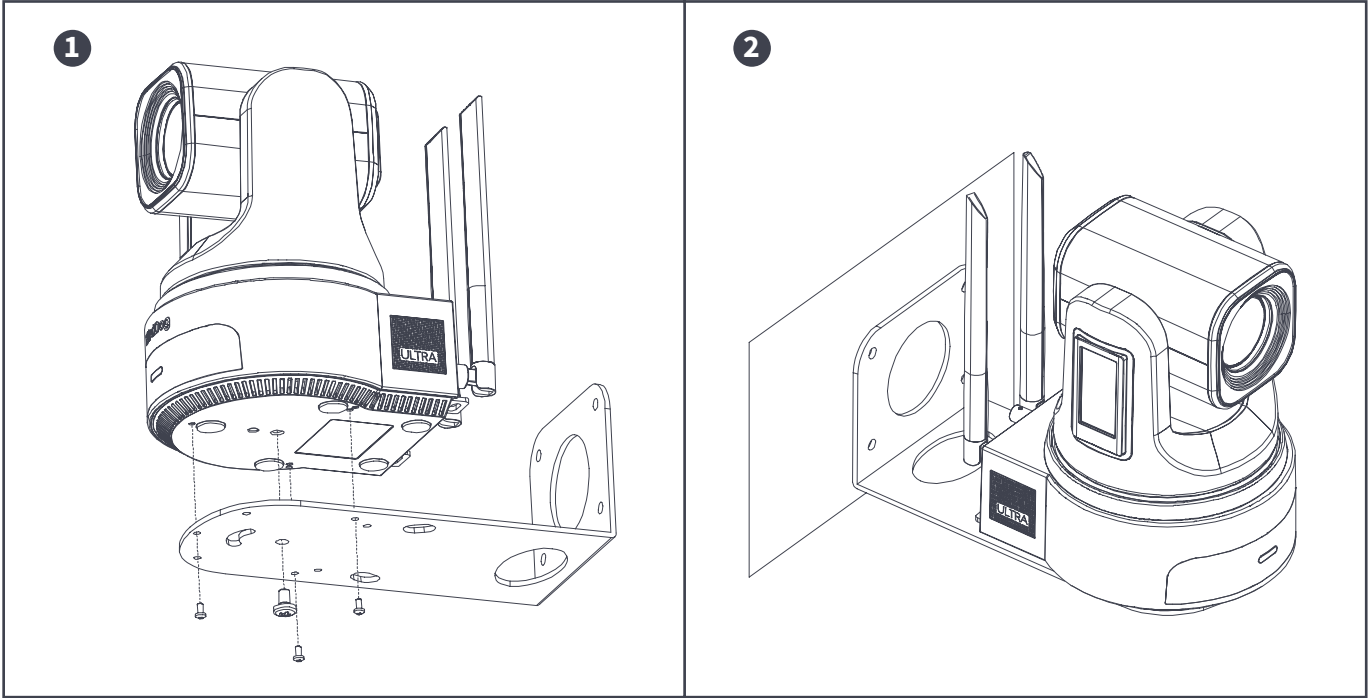

### Ceiling Mount

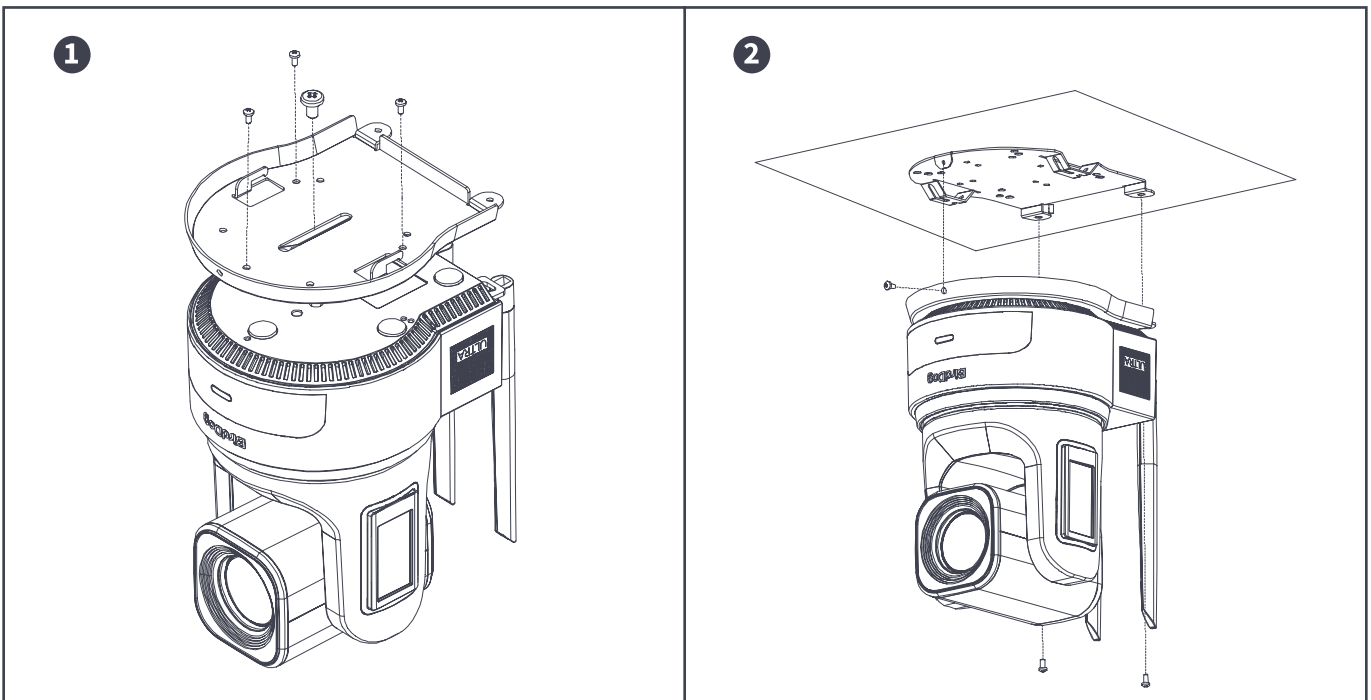

**Ceiling mount bracket:** 164.3\*141.5\*12.4 mm  
**Ceiling mount bracket screws:**  
 PWM3\*6 screws: 5 pcs (BOM list 7 pcs, with 2 extra included)  
 PM1/4#-20\*8 screw: 1 pc

**Wall mount bracket:** 228\*108\*95 mm  
**Wall mount bracket screws:**  
 PWM3\*8 screws: 3 pcs (BOM list 5 pcs, with 2 extra included)  
 PM1/4#-20\*10 screw: 1 pc

## CONNECTIONS & CONFIGURATIONS

---

### BASIC CONNECTIONS

---

#### Power

First off, you'll have to decide on how you are going to power the camera. You have three choices. You can use PoE+ (Power over Ethernet) or, if your network doesn't support PoE+, you can use the included 12VDC power adaptor. Lastly, you can decide to opt for the built-in battery. If available, PoE+ is the easier choice, since you can use the same Ethernet cable to power and control the camera, as well as send the video, audio and data. For the purposes of this quick start guide, we'll assume your network offers PoE+ (IEEE 802.3at).

#### Network

Connect your camera to a network switch with a Cat5/6 cable. By default, the camera is configured to automatically obtain an IP address via DHCP. Some standalone or private networks may not have a DHCP server. After 30 seconds of waiting for an automatically assigned IP address, your camera will fall back to a default address of 192.168.100.100. To ensure that you can always reach your camera, it is recommended that you don't change this default.

#### Power Up

When first powered up, the camera will perform its initialization routine by rotating to the left and then centering again.

### BASIC CONFIGURATION

---

#### NDI® Tools

NDI® Tools is a free suite of applications designed to introduce you to the world of IP video and is available at: <https://ndi.video/tools/>

Once installed, launch the Studio Monitor (Video Monitor, if using a Mac) application. This simple application allows you to view all NDI® sources on your network. Right click on the Studio Monitor window to view your camera as an NDI® source.

#### Tip

By default, the displayed sources have names that include the last five digits of your camera MAC address which is displayed on the bottom of the camera. Clicking on your camera in the source list will display the image from your camera with the default automatic settings.

## USING RS-232 / RS422 (VISCA)

You can use the RS-232 port to connect to optional controllers, such as a joystick keyboard controller, or PC control software, to operate the camera, perform pan, tilt and zoom operations, and to recall Preset positions using the control buttons.

3rd party computer applications can be used that support protocols available on the X4 Ultra.

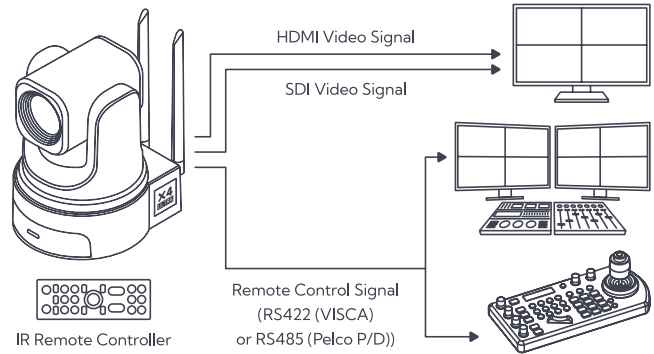

## RS232 CONNECTION

- In order to use a RJ45 to RS232 (VISCA) cable, the controller must be VISCA compatible.
- You can use CAT5/6 cable (T-568B standard pinout) to make an RS232 connection by following the pin definition here on the right side.
- You can use RS232 to daisy chain multiple camera connection with a standard RS232 serial port controller as on the right side.

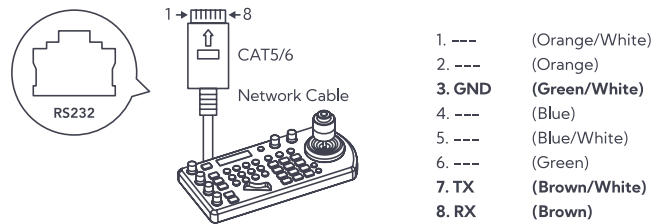

RS232 Serial port connection on controller side.

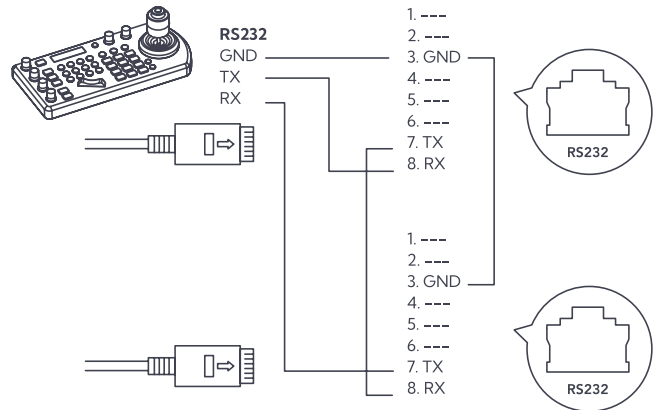

## WEB CONFIGURATION PANEL

BirdDog cameras have a web interface (also known as BirdUI) that is displayed by your computer browser and can be used to configure your camera remotely.

Please note that some features of the BirdUI interface are only available on some models. Please check System Specifications for camera capabilities.

In order to access the BirdUI interface you will need to scan the QR Code on your camera e-ink screen, or via web browser by inserting the correct address IP as a web link.

An alternative way to access the BirdUI is through NDI® Studio Monitor application:

Click on the gear icon on the bottom right of the Studio Monitor window.

In the displayed window, type the default password 'birddog' (all lower case) and click the OK button. The dashboard window is displayed.

When you first login, the system will prompt you to set your own password to maintain ongoing security.

The dashboard shows important basic camera settings. For now, check that the displayed Status is Active and take note of the frame rate that is currently output from the camera (displayed under NDI® connection info). This frame rate should be set identically for all cameras according to the requirements of your production.

**Note:** For more information about the BirdUI, please visit [BirdDog.tv/downloads](https://BirdDog.tv/downloads), or [BirdDog.tv/birdui-overview](https://BirdDog.tv/birdui-overview)

The screenshot shows the BirdDog PTZ X4 Ultra web configuration panel. The interface includes a sidebar with navigation options: Dashboard, Network, System, AV Setup, Cam Control, and Logout. The main content area displays various system metrics and settings:

- System Utilization:** A circular gauge showing 75% utilization.
- Network Status:** Ethernet Status: Not Connected; Wi-Fi Status: Connected; Preferred NIC: Wi-Fi.
- Wi-Fi Network:** BD-Office 2.4GHz.
- Status:** NDI Video Stream Name: CAM; Video Format: 1080p60; Audio Status: Mute.
- Stream Info:** Video Resolution: 1920x1080; Video Frame Rate: 59.94; Video Sample Rate: 4:2:2; Audio Channels: 2; Audio Sample Rate: 48000; Average Bitrate: 134Mbps; Genlock Status: Not Active; Network Mode: RUDP; Streaming Protocol: NDI HX.
- System Details:** System Name: birddog-12345; Eth. IP Address: 192.168.100.100; Firmware Version: BirdDog\_X4.0.2; MCU Version: 8; Wi-Fi IP Address: 192.168.100.5; Network Config Method: DHCP; Status: Active; MAC address: e8:eb:1b:49:a6:78.
- Device Restart:** A button labeled RESTART.
- System Reboot:** A button labeled REBOOT.



At the bottom of the sidebar, there are social media icons for Facebook, X, Instagram, YouTube, and LinkedIn, along with the BirdDog.tv logo.

## NETWORK SETUP



**BirdDog PTZ**  
 X4 Ultra

**Device Mode:** Encode  
**Source Status:** Streaming NDI





---

**Ethernet Network**

Wi-Fi Network

Configuration Method	<input checked="" type="button" value="STATIC"/> <input type="button" value="DHCP"/>	DHCP Timeout	<input type="text" value="20s"/>
IP Address	<input type="text" value="192.168.100.100"/>	DHCP Fallb. IP Address	<input type="text" value="192.168.100.100"/>
Subnet Mask	<input type="text" value="255.255.255.0"/>	SHCP Fallb. Sub. Mas k	<input type="text" value="255.255.255.0"/>
Gateway Address	<input type="text" value="192.168.100.1"/>	BirdDog Nam e	<input type="text" value="BirdDog-X4-Ult ra"/> <input type="text" value=".local"/>

 Dashboard

 **Network**

 System

## ETHERNET NETWORK CONFIGURATION

Most computer networks provide for both automatic and manual configuration of network devices and the X4 Ultra can accommodate both.

### Static or DHCP

Here you can set the network configuration to either DHCP (default) or Static. DHCP simplifies the management of IP addresses on networks. No two hosts can have the same IP address, so assigning them manually can potentially lead to errors. If your network is set up for DHCP, this is generally the best configuration to choose.

If you do choose to go with a Static IP address, you'll need to add the IP Address, Subnet Mask and Gateway Address information according to the requirements of your network.

### DHCP Timeout, Fallback IP address, Fallback Subnet Mask

You can set the timeout period during which the X4 Ultra will look for a DHCP IP address. After this period, the camera will default to the designated fallback IP address.



This can be useful if you use your camera in other network environments. For example, if a DHCP server is available in your normal office or studio application, the camera will use the DHCP supplied IP address. If you then use the camera in another application without a DHCP server, your camera will always default to the known fallover IP address.

### BirdDog Name

You can give your camera a meaningful name to make identification easier when viewing NDI® sources on a receiver such as a TriCaster, vMix or Studio Monitor. Be sure to make the name unique, as no two devices on the network should have the same name. The name can be any combination of 'a-z, 0-9, and -'.

After renaming your camera, navigate back to the Dashboard and click REBOOT DEVICE. The camera will re-initialize and you'll be good to go.

## WI-FI NETWORK CONFIGURATION

**BirdDog PTZ**  
X4 Ultra

Device Mode: Encode  
Source Status: Streaming NDI

Ethernet Network

**Wi-Fi Network**

Wi-Fi  ON  OFF

SSID:

- Custom
- BirdDog Office 2.4GHz
- WiFi Network 03
- WiFi Network 04
- WiFi Network 05
- WiFi Network 06
- WiFi Network 07

Configuration Method  STATIC  DHCP

IP Address

Subnet Mask

Gateway Address

BirdDog Name

Dashboard

Network

System

AV Setup

From the dedicated tab:

1. Click the Wi-Fi On button to enable Wi-Fi operation.
2. Select your network.
3. Complete the rest of the Wi-Fi configuration as for Ethernet Network Configuration above.
4. Click the Apply button to save your changes.

## AI TRACKING FROM BIRDUI (PRESENTER TRACKING)

The screenshot shows the BirdDog PTZ X4 Ultra web interface. The top bar displays 'BirdDog PTZ X4 Ultra', 'Device Mode: Encode', and 'Source Status: Streaming NDI'. The main interface is divided into several sections:

- Navigation Menu (Left):** Dashboard, Network, System, AV Setup, Cam Control, Logout.
- AI Tracking Section:**
  - AI Tracking: ON/OFF buttons.
  - Mode: PRESENTER (selected) / ZONE buttons.
  - Humanoid Frame: DEFAULT (selected) dropdown menu.
  - Tracking Hint: ON/OFF buttons.
- PTZ Control:** A directional pad with a home button.
- Zoom:** TELE/WIDE and IN/OUT buttons.
- Focus:** A button with an 'A' icon.
- Presenter Mode:**
  - Automations: Auto Zoom and Auto Tilt checkboxes.
  - Target Retention Time: Slider set to 30.
  - Figure Size Mode: Full dropdown menu.
  - Figure Size Adjustment: Slider set to 80.
  - Tracking Start Position: Current Location dropdown menu.
  - Character Position: Median dropdown menu.
- Preview:** A large box labeled 'BUILT-IN PREVIEW'.
- Footnote:**
  - When Auto Zoom or Tilt is off, camera stops zooming in/out or tilting automatically. Determine the zoom size and tilt position based on the tracking start position you choose.
  - Time to return to the starting point after losing the target.

### X4 Ultra AI Tracking User Guide

The X4 Ultra camera offers two AI tracking modes: Presenter (human-detection) tracking and Zone tracking. You can switch between these modes and adjust settings via the web interface or the remote control. Here's how each mode works:

#### Presenter (Human) Tracking

**Overview:** Presenter tracking follows a specific person based on AI human detection. You can control zoom levels, turn tracking on/off for certain areas, and adjust where the person appears on screen, all through the web interface. You can also decide whether to display tracking prompts.

#### Steps:

1. Open your web browser, enter the camera's IP address, and log in using your password to access the BirdUI Web Interface.
2. Go to CamControl > AI Tracking and select Presenter Mode.

#### Options:

##### 1. Humanoid Frame:

- **Default:** Shows a frame when multiple people are detected, allowing you to select a target using directional keys. The frame disappears once tracking begins.
- **Off:** No frame appears, ideal for live broadcasts.
- **Debug:** Keeps the frame visible, useful for testing or demos.

## 2. Tracking Hint:

- **On:** Displays a prompt in the top left corner when tracking starts.
- **Off:** No prompt, better for live broadcasts.

### Additional Settings:

- **Target Retention Time:** Time the camera waits before returning to the home position after losing the target (default: 6 seconds, up to 15 seconds).
- **Auto Zoom:** Adjusts zoom automatically if enabled.
- **Auto Tilt:** Moves the camera vertically when enabled.
  
- **Zoom Effect:**
  - **Full:** Shows the entire body.
  - **Upper:** Displays from the knees up.
  - **Close:** Shows from the waist up.
  - **Custom:** Manually set the frame size.
- **Tracking Start Position:** Choose between "Current Position" or "Preset Position 1."
- **Person Position in Frame:** Default is centered but can be adjusted to left or right.

**Enable Tracking:** Use directional keys to select a target, then press Home to confirm.

## AI TRACKING FROM BIRDUI (ZONE TRACKING)

The screenshot displays the BirdDog PTZ X4 Ultra web interface. The top header shows 'BirdDog PTZ X4 Ultra', 'Device Mode: Encode', and 'Source Status: Streaming NDI'. The main navigation menu on the left includes Dashboard, Network, System, AV Setup, Cam Control, and Logout. The central panel is titled 'AI Tracking' and is divided into several sections:

- AI Tracking Controls:** Includes 'ON' and 'OFF' buttons for AI Tracking, 'PRESENTER' and 'ZONE' buttons for Mode (with 'ZONE' selected), 'DEFAULT' for Humanoid Frame, and 'ON' and 'OFF' buttons for Tracking Hint.
- PTZ Control:** A directional pad with a central home button.
- Zoom:** 'TELE' and 'WIDE' buttons, and 'IN' and 'OUT' buttons for Focus.
- Zone Mode:** 'Zone Setting' dropdown (set to 'Zone D'), 'SAVE', and 'DELETE' buttons, and 'Tracking Start Area' dropdown (set to 'Zone B').
- Tracking Start Area:** Four thumbnails labeled A, B, C, and D.
- BUILT-IN PREVIEW:** A large empty rectangular area for the camera's live feed.

Footnotes at the bottom of the interface:

- When Auto Zoom or Tilt is off, camera stops zooming in/out or tilting automatically. Determine the zoom size and tilt position based on the tracking start position you choose.
- Time to return to the starting point after losing the target.

### Zone Tracking

**Overview:** Zone tracking divides the area into four zones (A, B, C, D), each linked to a preset camera position. When a person enters a zone, the camera automatically moves to that zone's preset.

#### Steps:

1. Enter the camera's IP address and log in to the BirdUI Web Interface.
2. Go to CamControl > AI Tracking and select Zone Mode.
3. Define up to 4 zones (A-D), always setting them from left to right. This feature is especially useful for classroom or event scenarios.
4. Treat each zone like a preset: when a person enters Zone A, tracking is triggered; as they leave Zone A, the camera automatically moves to Zone B, and so on.
5. After setting up the zones, click on a zone's thumbnail to activate Zone tracking. The camera will move to the selected zone and monitor for a person entering or leaving that zone.
6. Note that Zones B and C allow movements in both directions, while Zone A only triggers movement to Zone B, and Zone D only triggers movement to Zone C.

## OSD MENU OVERVIEW

---

### MENU

- ▶ Exposure
  - Color
  - Image
  - P/T/Z
  - Noise Reduction
  - Setup
  - Tracking Config
  - Communication Setup
  - Restore Default
  
- [Home] Enter
- [Menu] Exit

This camera menu structure is designed for professional users who require fine-tuned control over various settings to achieve optimal video quality. The settings are organized into logical categories, allowing you to configure exposure, color, image quality, P/T/Z control, noise reduction, setup options, and communication.

## 1. EXPOSURE

---

### EXPOSURE

- ▶ Mode                      Auto
- ExpCompMode            Off
- Backlight                Off
- Gain Limit                10
- Anti-Flicker             50Hz
- Meter                     Average
- DRC                        1
  
- ▲▼ Select Item
- ◀▶ Change Value
- [Menu] Exit

Exposure settings control how much light the camera captures, directly affecting the image’s brightness, contrast, and detail visibility in both well-lit and low-light environments.

**Mode (Auto/Manual/SAE/AAE/Bright):** Determines how exposure is adjusted based on the scene.

- **Auto:** The camera automatically adjusts exposure to balance lighting conditions, ideal for situations where light changes frequently.
  - **ExposureCompMode (Off/On):** Toggles exposure compensation, which adjusts for backlighting or uneven lighting conditions.
    - **ExpComp (-7/+7):** Fine-tunes exposure to increase or decrease brightness. Use positive values for underexposed scenes or negative values for overexposed conditions.
  - **Backlight (Off):** If turned on, this feature enhances detail in backlit scenes, useful for capturing subjects against bright backgrounds (e.g., windows, bright lights).
  - **Gain Limit (0 to 15):** Restricts maximum gain to reduce noise, helpful for maintaining image quality in low-light conditions.
  - **Anti-Flicker (50Hz/60Hz):** Matches the camera's refresh rate to artificial lighting frequency to eliminate flickering. Set to 50Hz in regions with 50Hz power frequency (e.g., Europe) or 60Hz for 60Hz regions (e.g., USA).
  - **Meter (Average/Centre/Smart/Top):** Defines the metering mode, which determines how the camera measures the light across the frame.
    - **Average:** Measures overall light across the frame; good for evenly lit scenes.
    - **Centre:** Prioritizes the center of the frame; useful for focusing on a centered subject.
    - **Smart:** Dynamically adjusts metering based on detected subjects or faces.
    - **Top:** Focuses on the upper part of the frame, ideal for scenes where light sources are overhead.
- **DRC (1 to 8):** Adjusts dynamic range to manage highlights and shadows, enhancing details in high-contrast scenes. Higher values increase detail in both bright and dark areas.

**Manual:** Provides complete control over exposure settings, suitable for static lighting conditions or professional adjustments.

- **Iris (e.g., F1.8):** Controls the aperture size; lower values (e.g., F1.8) allow more light, while higher values (e.g., F11) reduce light intake. Use wider apertures for low light or a shallow depth of field.
- **Shutter (e.g., 1/125):** Sets the speed at which the shutter opens and closes. Faster shutter speeds (e.g., 1/250 or 1/500) are recommended for capturing fast motion, while slower speeds (e.g., 1/30) enhance light intake but may introduce motion blur.
- **Gain (0 to 7):** Amplifies the video signal to boost brightness in low-light scenes. Lower values (e.g., 0-2) produce cleaner images, while higher values increase noise.
- **DRC (1 to 8):** Manually adjusts dynamic range for balanced contrast in high-contrast scenes.

**SAE (Shutter Priority Auto Exposure):** Fixes the shutter speed while the camera automatically adjusts other parameters (gain, iris) to maintain optimal exposure.

- **Shutter:** Select based on motion capture requirements (e.g., 1/500 for fast sports, 1/60 for general scenes).
- **Gain Limit and Meter:** Same as in Auto mode.
- **DRC:** Enhances shadow detail while maintaining highlights.

**AAE (Aperture Priority Auto Exposure):** Fixes the iris setting, allowing the camera to adjust other parameters automatically. This mode is ideal for controlling depth of field while keeping exposure stable.

- **Iris:** Adjust for desired background blur.

- **Anti-Flicker/Meter/DRC:** Same as in Auto mode.

**Bright:** Maximizes image brightness in extremely low-light conditions.

- **Bright (0 to 17):** Sets a high brightness level by increasing gain and other parameters. Recommended for dimly lit areas like night scenes.
- **Gain Limit:** Restricts maximum gain to reduce excessive noise.

## 2. COLOR

---

### COLOR

▶ WB Mode	Auto
RG Tuning	0
BG Tuning	0
Saturation	100%
Hue	7

▲▼ Select Item

◀▶ Change Value

[Menu] Exit

Color settings affect white balance, saturation, and hue, helping achieve accurate color reproduction under various lighting conditions.

**WB Mode (Auto/Indoor/Outdoor/OnePush/Manual/Var):** Controls white balance to ensure correct color temperature adjustments.

- **Auto:** Automatically adjusts color balance to maintain natural colors, suitable for varying lighting.
- **Indoor:** Preset for indoor lighting, optimizing color for warmer light sources like tungsten or fluorescent.
- **Outdoor:** Calibrates for daylight conditions, adjusting for cooler, blue-tinted light.
- **OnePush:** Adjusts white balance based on a single reference point. Use this option when lighting is stable but may vary from default settings.
- **Manual:** Manually sets white balance, providing precise control over color accuracy.
- **VAR:** Allows adjustment of white balance by setting a specific color temperature.
- **Color Temp (2500K to 8000K):** Adjusts to warm (lower values) or cool (higher values) lighting. Use lower values for warm light sources and higher for daylight or blue-tinted light.
- **RG/BG Tuning (-10 to +10):** Fine-tunes red/blue gain, helping correct color shifts.
- **Saturation (60% to 200%):** Adjusts the intensity of colors. Higher values produce vivid colors, while lower values are muted.
- **Hue (0 to 14):** Modifies the overall color tone, shifting it towards warmer or cooler hues.

## IMAGE

---

### IMAGE

▶ Luminance	7
Contrast	7
Sharpness	6
Flip H	Off
Flip V	Off
B&W Mode	Off
Gamma	Default
Style	Default

▲▼ Select Item

◀▶ Change Value

[Menu] Exit

Image settings enhance visual quality by adjusting contrast, sharpness, and other characteristics.

- **Luminance (0 to 14):** Adjusts image brightness independently of exposure settings. Higher values increase overall brightness.
- **Contrast (0 to 14):** Increases the difference between the darkest and brightest parts of the image. Use higher values for dramatic effects, lower values for flatter images.
- **Sharpness (0 to 11):** Defines the edge clarity of objects in the frame. High values enhance detail but may introduce noise.
- **Flip H/Flip V (Off/On):** Flips the image horizontally or vertically, useful for adjusting camera orientation in inverted setups.
- **B&W Mode (Off):** Converts the image to black and white for creative or surveillance purposes.
- **Gamma (Default/0.45/0.48/0.5/0.56/PC):** Adjusts the image's mid-tone brightness. Lower gamma (e.g., 0.45) enhances contrast, while higher gamma reduces contrast.
- **Style (Default/Norm/Bright/PC):** Applies predefined image processing styles for different visual effects:
  - **Default:** Balanced look.
  - **Norm:** Natural tone.
  - **Bright:** Increases brightness and contrast.
  - **PC:** Optimized for computer display.

## P/T/Z (PAN, TILT, ZOOM)

### P/T/Z

▶ SpeedByZoom	On
AF-Zone	Front
AF-Sense	High
L/R Set	STD
Display Info	Off
Image Freeze	Off
Digital Zoom	Off
Call Preset Speed	7
Pre Zoom Speed	5

- ▲▼ Select Item
- ◀▶ Change Value
- [Menu] Exit

The P/T/Z menu allows for control of camera movement and zoom.

- **SpeedByZoom (On):** Adjusts pan/tilt speed based on zoom level, automatically slowing down when zoomed in for smoother tracking.
- **AF Zone (Front/Top/Center/Bottom):** Sets the area where autofocus is most sensitive, useful for focusing on a subject in a specific part of the frame.
- **AF Sense (High/Low/Normal):** Adjusts autofocus sensitivity, with higher sensitivity recommended for fast-moving subjects.
- **L/R Set (STD/REV):** Controls left/right movement orientation; reverse settings if needed.
- **Display Info (Off/On):** Toggles on-screen display information like zoom level and camera status.
- **Image Freeze (Off/On):** Freezes the image during Preset recalling to avoid movement in live broadcasts.
- **Digital Zoom (Off/2x/4x/8x/16x):** Allows digital zooming up to 16x, but may reduce image quality at higher levels.
- **Call Preset Speed (1 to 24):** Sets the speed for recalling preset positions.
- **Pre Zoom Speed (1 to 7):** Controls zoom speed when moving to preset positions.

## NOISE REDUCTION

---

### NOISE REDUCTION

▶ NR3D-Level            5

▲▼ Select Item

◀▶ Change Value

[Menu] Exit

Reduces noise in low-light conditions, which is crucial for maintaining image clarity.

- **NR3D-Level (Off to 9):** Adjusts 3D noise reduction. Higher levels offer more noise reduction but may soften the image. Use lower levels to maintain more detail.

## SETUP

---

### SETUP

▶ Language            EN  
 DVI Mode            HDMI  
 Video Format        1080P60  
 Auto Patrol         Off  
 Video Mode  
 Other

▲▼ Select Item

◀▶ Change Value

[Menu] Exit

General system settings and video output configurations.

- **Language (e.g., EN):** Sets the interface language.
- **DVI Mode (HDMI/DVI):** Selects video output format, with HDMI typically used for high-definition displays and DVI for computer monitors.
- **Video Format (e.g., 1080P60):** Defines the video resolution and frame rate. Use 1080P50/60 or 2160P50/60 for smooth motion.
- **Auto Patrol (Off):** Activates automated panning to monitor an area.
  - **Auto Patrol Residence Time (1 to 60s):** Time spent at each preset position.
  - **Auto Patrol Call Preset Speed (1 to 24):** Speed of movement between preset positions.

- **Video Mode**
  - **SDI-3G Mode (Level-A/Level B):** Selects SDI output format, with Level-A typically used for broadcast video equipment.
  - **Video Output (HDMI/SDI):** Selects primary video output.
- **Setup/Other**
  - **Auto Inversion (On):** Automatically flips the image when the camera is mounted upside down.
  - **Tally Mode (On):** Controls tally lights to indicate live broadcast.

## 7. TRACKING CONFIG

---

**TRACKING CONFIG**

▶	Tracking	Off
	Tracking Mode	Presenter
	Figure Size	Full

▲▼ Select Item  
 ◀▶ Change Value  
 [Menu] Exit

Configures the camera’s AI tracking capabilities. Please see the AI Tracking section of this manual for more information.

- **Tracking (Off/On):** Enables AI-based subject tracking.
- **Tracking Mode (Presenter/Zone):** Sets whether the camera tracks a moving presenter or is triggered from a defined zone.
- **Figure Size (Full/Half Body/Close Up/Custom):** Sets the frame size for tracking. Custom allows manual frame size definition for different shot types.

## 8. COMMUNICATION SETUP

---

### COMMUNICATION SETUP

▶ Protocol	VISCA
V_Address	1
V_AddrFix	Off
Net Mode	Serial
Baudrate	9600

- ▲▼ Select Item
- ◀▶ Change Value
- [Menu] Exit

Configures remote control protocols and network settings. Note that the camera will always respond to VISCA-IP and NDI protocols.

- **Protocol (VISCA/PELCO-D/PELCO-P/Auto):** Sets the communication protocol used for camera control.
- **V\_Address (1):** Sets the VISCA device address.
- **V\_AddrFix (Off):** Enables or disables fixed address mode for VISCA.
- **Net Mode (Serial):** Defines communication over a serial interface.
- **P\_D Address/P\_P Address:** Sets PELCO-D/P addresses for communication.
- **Baudrate (9600):** Sets communication speed; higher baud rates are faster but may reduce stability.

## 9. RESTORE DEFAULT

---

Resets all settings to factory defaults, useful for troubleshooting or restoring initial settings.

## CAMERA DIMENSIONS

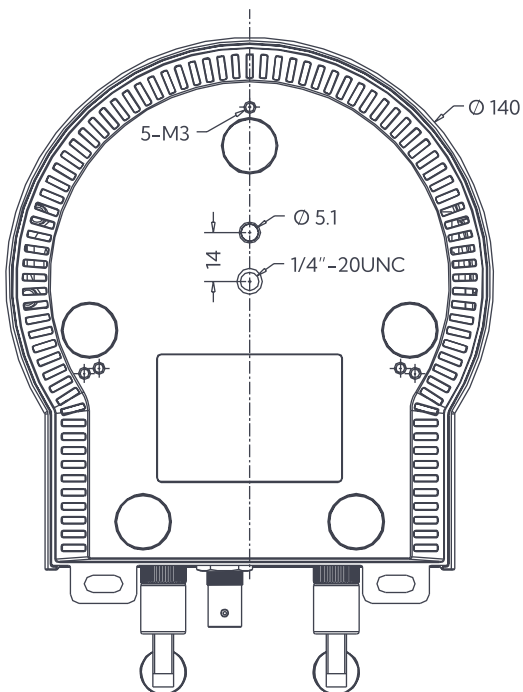
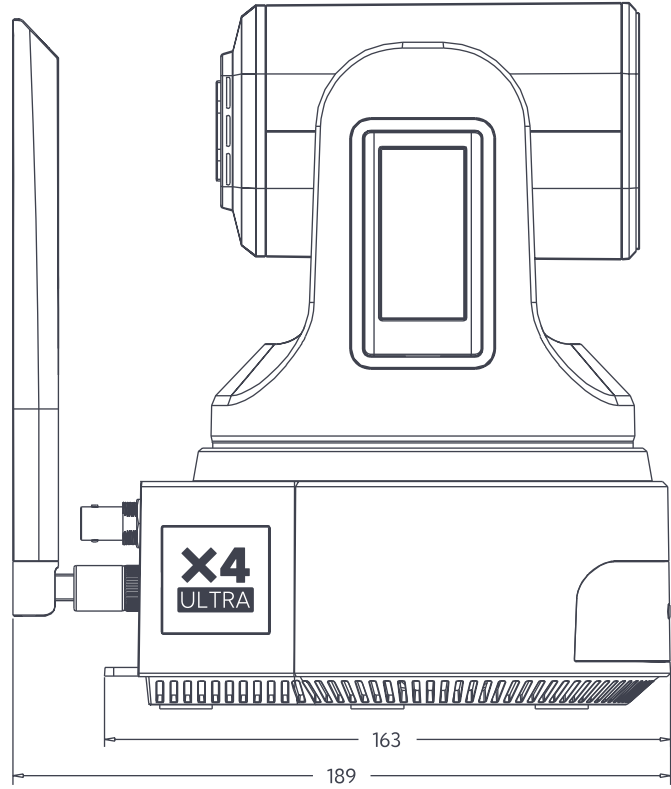
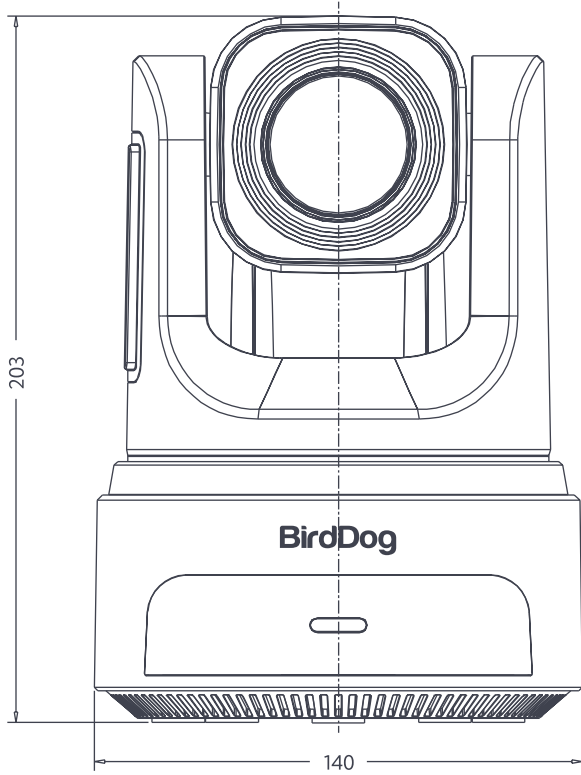

## TROUBLESHOOTING

---

### IMAGE

---

**The monitor shows no image.**

Ensure that the camera power supply is connected, the voltage is normal, and the power indicator is always on. Turn off the power switch to check that the camera is self-testing. Ensure the cable of video platform and TV that in correct connection.

**Image jitters after the camera is properly connected.**

Ensure that the camera installation is in stable position. Check that any vibrating machinery or object near the camera.

**There is no video image in browser.**

It is recommended to use a modern Internet browser such as Google Chrome, Firefox, or Safari to interact successfully with the camera. Other browsers may have unexpected issues.

**Unable to access camera through the browser.**

Using PC to access the network, test that other network tasks like internet browsing are working correctly. Reset the network connectors at the camera and your computer, and reboot your camera. Ensure that the IP address, subnet mask and gateway settings match your network configuration. Check that there are no IP address conflicts.

**Forgotten IP address or login password.**

The default IP address is: 192.168.100.100;  
The default password is: 'birddog'.

If you forget the camera IP address or password, using the supplied IR remote control, press the [\*] + [#] + [Manual] keys in sequence to restore system default settings.

After restoring the defaults, you will need to set a strong password again when first logging in to the BirdUI webpage.

### CONTROL

---

**Remote control does not work**

Check and replace batteries with new batteries.  
Ensure that the camera is operating normally.  
Ensure that the address key of remote control matches the camera number set in the OSD.

**Cannot control camera over the serial port**

1. Ensure that the protocol, address and bit rate of the camera are consistent.
2. Ensure that the control cable is properly connected.

## WARRANTY

---

### **5 Year Warranty**

BirdDog X-series cameras feature a 5 year, global warranty. BirdDog prides itself on delivering the best possible products to customers, but if something was to go wrong, you can rest assured knowing that no matter where in the world you are, BirdDog has your back.

Read more at [BirdDog.tv/warranty-terms](https://BirdDog.tv/warranty-terms)



BirdDog.tv